

# MCQI3 series

ISO 15552 STANDARD PROFILE CYLINDER



## Table for standard stroke

Tube I.D.	Stroke (mm)	Max. stroke (mm)
ø32, 40	50, 75, 100, 125, 150, 175,	1800
ø50, 63	200, 250, 300, 350, 400,	2000
ø80, 100	450, 500, 600, 700, 800	2500

\* Please contact us if the stroke is out of specification.

## Order example

MCQI3 – 11 – 63 – 100 M – S – T

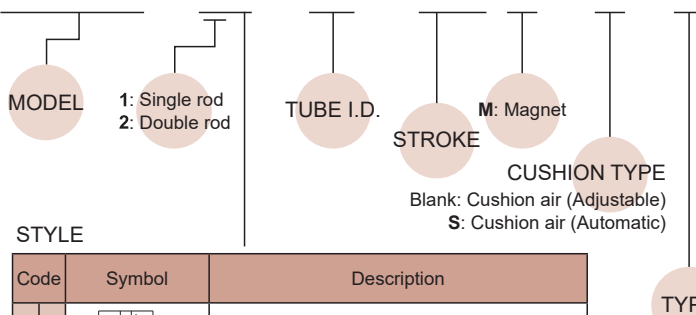

T: With magnet, TA/TB is assembled

\* Tube, piston rod and tie rod are extended, and an extra piston is added.

\* Order example for special specification, refer to page 0-7.

\* Rc or NPT thread are also available, please contact us.

## Features

### ■ Non lubrication

Special housing and bushing enables self lubrication of piston rod.

### ■ High quality long service life

Hard anodised aluminium cylinder tubes offer a high resistance to corrosion and low internal friction.

### ■ Automatic air cushioning

Pneumatic cushioning at both ends without adjusting.

### ■ Low noise level

Add cushion pad to reduce impact sound and vibration.

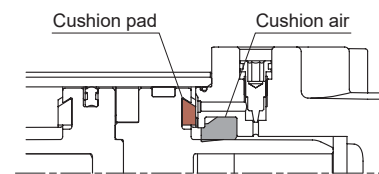

### ■ ISO 15552 standard specification

Conforms to ISO 15552 specification enabling worldwide interchangeability.

### ■ Easy to insert reed switch

With four grooves on the tube, proximity and reed sensors can be easily inserted into any position.

## Specification

Model	MCQI3
Tube I.D. (mm)	32, 40, 50, 63, 80, 100
Medium	Air
Operating pressure range	0.05~1 MPa
Proof pressure	1.5 MPa
Ambient temperature	-5~+60°C (No freezing)
Available speed range	50~500 mm/sec
Sensor switch	RCI (Please refer to page 8-14)

# MCQI3 Order example of accessories

ISO 15552 STANDARD PROFILE CYLINDER



## Accessories & Connector

Accessories							
Code	LB (Purchase 2 pcs)	CA	CA2	CB	CB2	CDB (Purchase CB+PIN)	CDB2 (Purchase CB+PIN)
Mounting Tube I.D.							
ø32	LB-Q2-32	CA-Q2-32	CA2-Q2-32	CB-Q2-32	CB2-Q2-32	CDB-Q2-32	CDB2-Q2-32
ø40	LB-Q2-40	CA-Q2-40	CA2-Q2-40	CB-Q2-40	CB2-Q2-40	CDB-Q2-40	CDB2-Q2-40
ø50	LB-Q2-50	CA-Q2-50	CA2-Q2-50	CB-Q2-50	CB2-Q2-50	CDB-Q2-50	CDB2-Q2-50
ø63	LB-Q2-63	CA-Q2-63	CA2-Q2-63	CB-Q2-63	CB2-Q2-63	CDB-Q2-63	CDB2-Q2-63
ø80	LB-Q2-80	CA-Q2-80	CA2-Q2-80	CB-Q2-80	CB2-Q2-80	CDB-Q2-80	CDB2-Q2-80
ø100	LB-Q2-100	CA-Q2-100	CA2-Q2-100	CB-Q2-100	CB2-Q2-100	CDB-Q2-100	CDB2-Q2-100

Accessories				Rod nut	
Code	FAC	FBC	FAC2	FBC2	NUT
Mounting Tube I.D.					
ø32	FAC-Q2-32		FAC2-Q2-32		NUT-M10x1.25x5Hx17B
ø40	FAC-Q2-40		FAC2-Q2-40		NUT-M12x1.25x6Hx19B
ø50	FAC-Q2-50		FAC2-Q2-50		NUT-M16x1.5x8Hx24B
ø63	FAC-Q2-63		FAC2-Q2-63		
ø80	FAC-Q2-80		FAC2-Q2-80		NUT-M20x1.5x10Hx30B
ø100	FAC-Q2-100		FAC2-Q2-100		

Accessories  Factory assembled and shipped (self-assembled is not recommended)			Connector			
Code	TA	TB	TC	Y	I	YS (Y+Floating pin)
Mounting Tube I.D.						
ø32		TC-Q3-32		Y-Q2-32	I-Q2-32	YS-Q2-32
ø40		TC-Q3-40		Y-Q2-40	I-Q2-40	YS-Q2-40
ø50		TC-Q3-50		Y-Q2-50	I-Q2-50	YS-Q2-50
ø63		TC-Q3-63				
ø80		TC-Q3-80		Y-Q2-80	I-Q2-80	YS-Q2-80
ø100		TC-Q3-100				

## Pin

Applicable	YS connector	Y&I connector	CA&CB accessories
Code	PIN-S	PIN-Y-P (with split pin)	PIN-CB-P (with split pin)
Fig Tube I.D.			
ø32	PIN-Q2-32-S	PIN-Q2-32-2-P	PIN-Q2-32-1-P
ø40	PIN-Q2-40-S	PIN-Q2-40-2-P	PIN-Q2-40-1-P
ø50	PIN-Q2-50-S	PIN-Q2-50-2-P	PIN-Q2-50-1-P
ø63			PIN-Q2-63-1-P
ø80	PIN-Q2-80-S	PIN-Q2-80-2-P	PIN-Q2-80-1-P
ø100			PIN-Q2-100-1-P

## Order example of self-assembled

The tube I.D. ø40 of LB accessories, Y connector and pin.

No.	Order number	Qty
1	LB-Q2-40	2
2	Y-Q2-40	1
3	PIN-Q2-40-2-P	1

\* To order accessories/ connectors/ pin separately, please place orders separately according to the order codes in the above table.

## Order example of factory assembled

Cylinders and accessories are distinguished by the symbol "+".

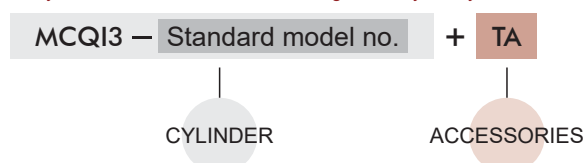

# MCQI3-11 Inside structure & Parts list

ISO 15552 STANDARD PROFILE CYLINDER



## Single rod 11 type

Cushion air (Adjustable)

ø32, ø40

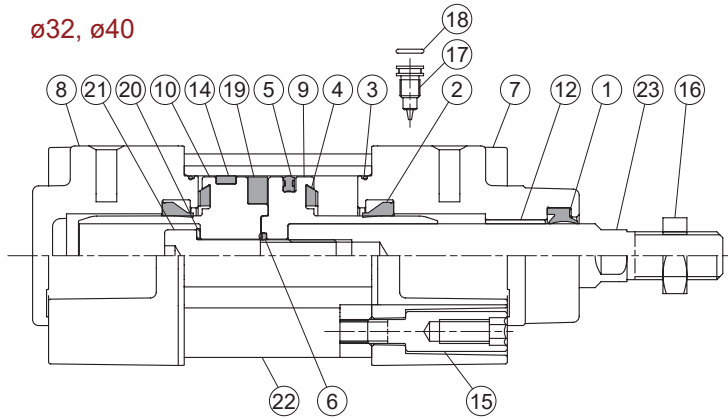

ø50

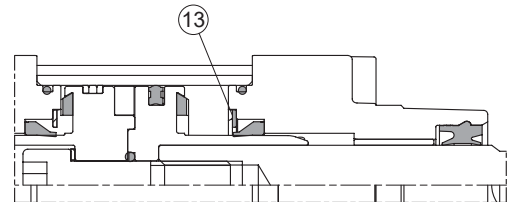

ø63

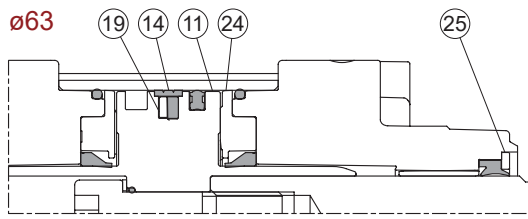

ø80, ø100

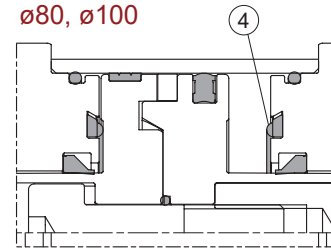

## Material

No.	Part name	Material	Q'y	Component parts (inclusion)	Repair kits (inclusion)	Note
1	Rod packing	NBR	1	●	●	Repair kits ø50 not included
2	Cushion packing	NBR	2	●	●	
3	O-ring	NBR	2	●	●	
4	Cushion pad	NBR	2	●	●	
5	Piston packing	NBR	1	●	●	
6	O-ring	NBR	1	●	●	
7	Rod cover	Aluminum alloy	1	●		
8	Head cover	Aluminum alloy	1	●		
9	Piston #1	Aluminum alloy	1	●		
10	Piston #2	Aluminum alloy	1	●		
11	Piston	Aluminum alloy	1	●		Only for ø63
12	Bush	Bearing alloy	1	●		
13	Washer	Carbon steel	2	●		Only for ø50
14	Wear ring	Resin	1	●		
15	Screw	Carbon steel	8	●		
16	Piston rod nut	Carbon steel	1	●		
17	Needle valve	Copper alloy	2	●		
18	O-ring	NBR	2	●		
19	Magnet ring	Magnet material	1	◎		◎ Option
20	Washer	Carbon steel	1	●		
21	Hex bolt	Carbon steel	1	●		
22	Cylinder tube	Aluminum alloy	1			
23	Piston rod *1	Carbon steel	1			
24	Cushion seal holder	Aluminum alloy	2	●		Only for ø63
25	Washer	Carbon steel	1	●		Only for ø63

\*1. When customized material is bearing steel, only two-side across flat (wrench flat) is available.

# MCQI3-11-S Inside structure & Parts list

ISO 15552 STANDARD PROFILE CYLINDER



## Single rod 11 type

Cushion air (Automatic)

ø32, ø40

ø50

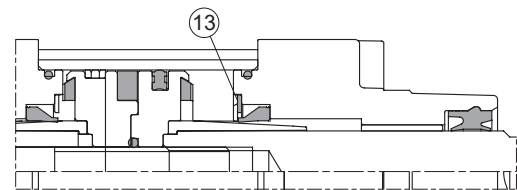
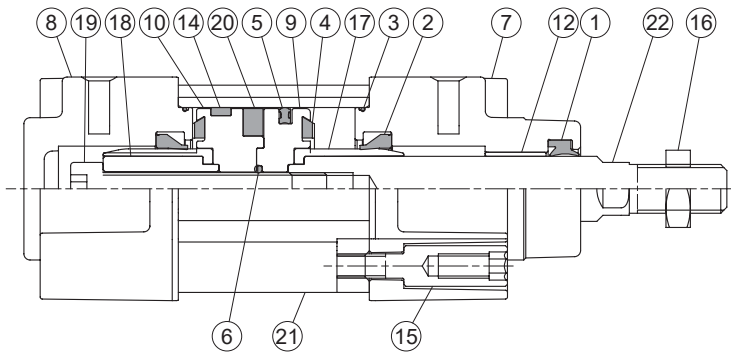

ø63

ø80, ø100

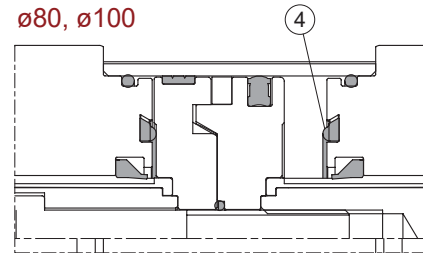
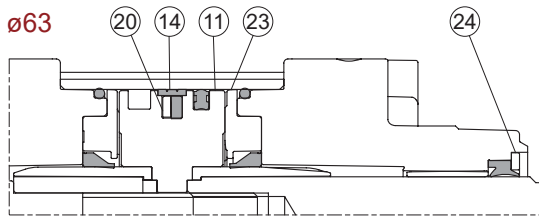

## Material

No.	Part name	Material	Q'y	Component parts (inclusion)	Repair kits (inclusion)	Note
1	Rod packing	NBR	1	●	●	Repair kits ø50 not included
2	Cushion packing	NBR	2	●	●	
3	O-ring	NBR	2	●	●	
4	Cushion pad	NBR	2	●	●	
5	Piston packing	NBR	1	●	●	
6	O-ring	NBR	1	●	●	
7	Rod cover	Aluminum alloy	1	●		
8	Head cover	Aluminum alloy	1	●		
9	Piston #1	Aluminum alloy	1	●		
10	Piston #2	Aluminum alloy	1	●		
11	Piston	Aluminum alloy	1	●		Only for ø63
12	Bush	Bearing alloy	1	●		
13	Washer	Carbon steel	2	●		Only for ø50
14	Wear ring	Resin	1	●		
15	Screw	Carbon steel	8	●		
16	Piston rod nut	Carbon steel	1	●		
17	Shock absorber axis	Resin	2	●		
18	Piston nut	Aluminum alloy	1	●		
19	Hex bolt	Carbon steel	1	●		
20	Magnet ring	Magnet material	1	◎		◎ Option
21	Cylinder tube	Aluminum alloy	1			
22	Piston rod *1	Carbon steel	1			
23	Cushion seal holder	Aluminum alloy	2	●		Only for ø63
24	Washer	Carbon steel	1	●		Only for ø63

\*1. When customized material is bearing steel, only two-side across flat (wrench flat) is available.

# MCQI3-21/27 Inside structure & Parts list

ISO 1552 STANDARD PROFILE CYLINDER



## Double rod 21 / 27 type

Cushion air (Adjustable)

ø32, ø40

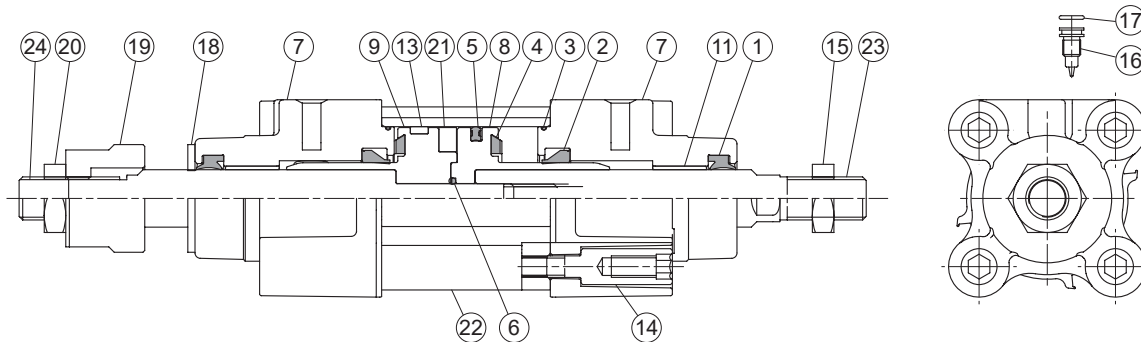

ø50

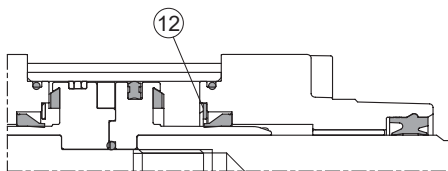

ø63

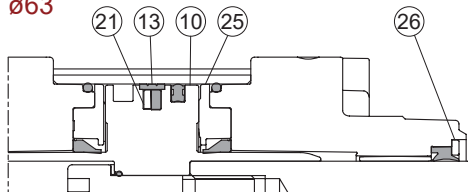

ø80, ø100

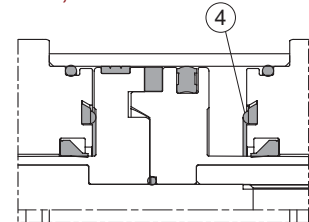

## Material

No.	Part name	Material	Q'y	Component parts (inclusion)		Repair kits (inclusion)	Note
				21 type	27 type		
1	Rod packing	NBR	2	●	●	●	Repair kits ø50 not included
2	Cushion packing	NBR	2	●	●	●	
3	O-ring	NBR	2	●	●	●	
4	Cushion pad	NBR	2	●	●	●	
5	Piston packing	NBR	1	●	●	●	
6	O-ring	NBR	1	●	●	●	
7	Rod cover	Aluminum alloy	2	●	●		
8	Piston #1	Aluminum alloy	1	●	●		
9	Piston #2	Aluminum alloy	1	●	●		
10	Piston	Aluminum alloy	1	●	●		Only for ø63
11	Bush	Bearing alloy	2	●	●		
12	Washer	Carbon steel	2	●	●		Only for ø50
13	Wear ring	Resin	1	●	●		
14	Screw	Carbon steel	8	●	●		
15	Piston rod nut	Carbon steel	1	●	●		
16	Needle valve	Copper alloy	2	●	●		
17	O-ring	NBR	2	●	●		
18	Gasket	PU	1		●		
19	Adjustable nut	Carbon steel	1		●		
20	Hex nut	Carbon steel	1		●		
21	Magnet ring	Magnet material	1	◎	◎		◎ Option
22	Cylinder tube	Aluminum alloy	1				
23	Piston rod #1 *1	Carbon steel	1				
24	Piston rod #2 *1	Carbon steel	1				
25	Cushion seal holder	Aluminum alloy	1	●	●		Only for ø63
26	Washer	Carbon steel	1	●	●		Only for ø63

\*1. When customized material is bearing steel, only two-side across flat (wrench flat) is available.

# MCQI3-21/27-S Inside structure & Parts list

ISO 1552 STANDARD PROFILE CYLINDER



## Double rod 21 / 27 type

Cushion air (Automatic)

ø32, ø40

ø50

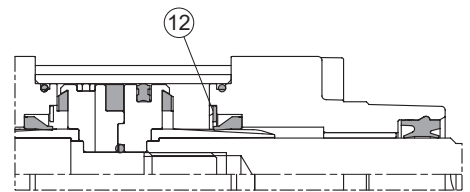
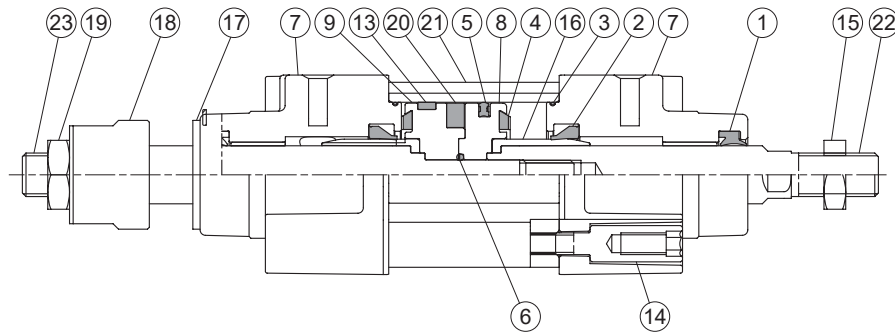

ø63

ø80, ø100

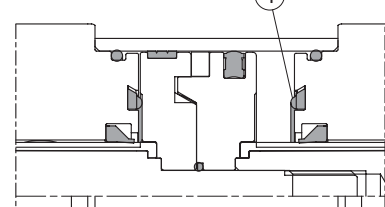
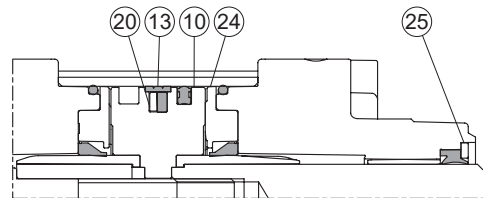

## Material

No.	Part name	Material	Q'y	Component parts (inclusion)		Repair kits (inclusion)	Note
				21 type	27 type		
1	Rod packing	NBR	2	●	●	●	Repair kits ø50 not included
2	Cushion packing	NBR	2	●	●	●	
3	O-ring	NBR	2	●	●	●	
4	Cushion pad	NBR	2	●	●	●	
5	Piston packing	NBR	1	●	●	●	
6	O-ring	NBR	1	●	●	●	
7	Rod cover	Aluminum alloy	2	●	●		
8	Piston #1	Aluminum alloy	1	●	●		
9	Piston #2	Aluminum alloy	1	●	●		
10	Piston	Aluminum alloy	1	●	●		Only for ø63
11	Bush	Bearing alloy	2	●	●		
12	Washer	Carbon steel	2	●	●		Only for ø50
13	Wear ring	Resin	1	●	●		
14	Screw	Carbon steel	8	●	●		
15	Piston rod nut	Carbon steel	1	●	●		
16	Shock absorber axis	Resin	2	●	●		
17	Gasket	PU	1		●		
18	Adjustable nut	Carbon steel	1		●		
19	Hex nut	Carbon steel	1		●		
20	Magnet ring	Magnet material	1	◎	◎		◎ Option
21	Cylinder tube	Aluminum alloy	1				
22	Piston rod #1 *1	Carbon steel	1				
23	Piston rod #2 *1	Carbon steel	1				
24	Cushion seal holder	Aluminum alloy	1	●	●		Only for ø63
25	Washer	Carbon steel	1	●	●		Only for ø63

\*1. When customized material is bearing steel, only two-side across flat (wrench flat) is available.

# MCQI3 Component parts & Repair kits



ISO 15552 STANDARD PROFILE CYLINDER

## Order example of component parts

CP – MCQI3 – 2 – 63 M S

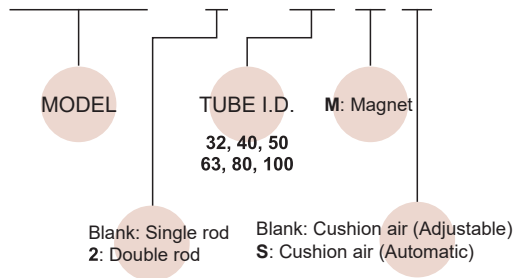

## Order example of repair kits

PS – MCQI3 – 2 – 63 S – XB6

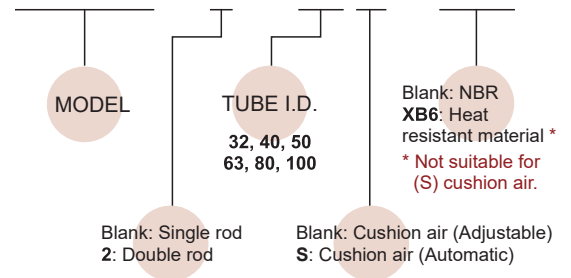

\* Order example for Rc or NPT thread please contact us.

## Cylinder & accessories weight

### Cylinder weight

Unit: kg

Model	Basic weight MCQI3-11	Basic weight (magnet) MCQI3-11	Basic weight MCQI3-11-S	Basic weight (magnet) MCQI3-11-S	Stroke 25 mm MCQI3-11-(S)
Tube I.D.					
ø32	0.534	0.540	0.531	0.537	0.062
ø40	0.789	0.801	0.783	0.795	0.088
ø50	1.300	1.317	1.293	1.310	0.120
ø63	1.785	1.805	1.774	1.794	0.129
ø80	2.653	2.680	2.638	2.665	0.185
ø100	3.949	3.984	3.885	3.920	0.236

### Accessories weight

Unit: kg

Model	LB	CA	CA2	CB	CB2	CDB	CDB2	FAC/ FBC	FAC2/ FBC2	TA/TB/TC
Tube I.D.										
ø32	0.163	0.213	0.07	0.185	0.07	0.170	0.06	0.235	0.07	0.208
ø40	0.211	0.253	0.09	0.211	0.10	0.230	0.08	0.265	0.09	0.282
ø50	0.315	0.390	0.16	0.352	0.15	0.410	0.12	0.460	0.17	0.377
ø63	0.395	0.670	0.23	0.544	0.23	0.550	0.18	0.684	0.20	0.675
ø80	0.816	1.076	0.40	0.982	0.45	0.870	0.28	1.508	0.40	1.025
ø100	1.014	1.587	0.50	1.493	0.60	1.400	0.45	1.975	0.56	1.680

Model	Y	I	Pin		YS
			Y / I	CA / CB	
Tube I.D.					
ø32	0.070	0.080	0.02	0.040	0.018
ø40	0.115	0.141	0.03	0.065	0.031
ø50	0.272	0.334	0.08	0.072	0.070
ø63	0.272	0.334	0.08	0.145	0.070
ø80	0.551	0.553	0.16	0.179	0.150
ø100	0.551	0.553	0.16	0.330	0.150

# MCQI3 Accessories

ISO 1552 STANDARD PROFILE CYLINDER

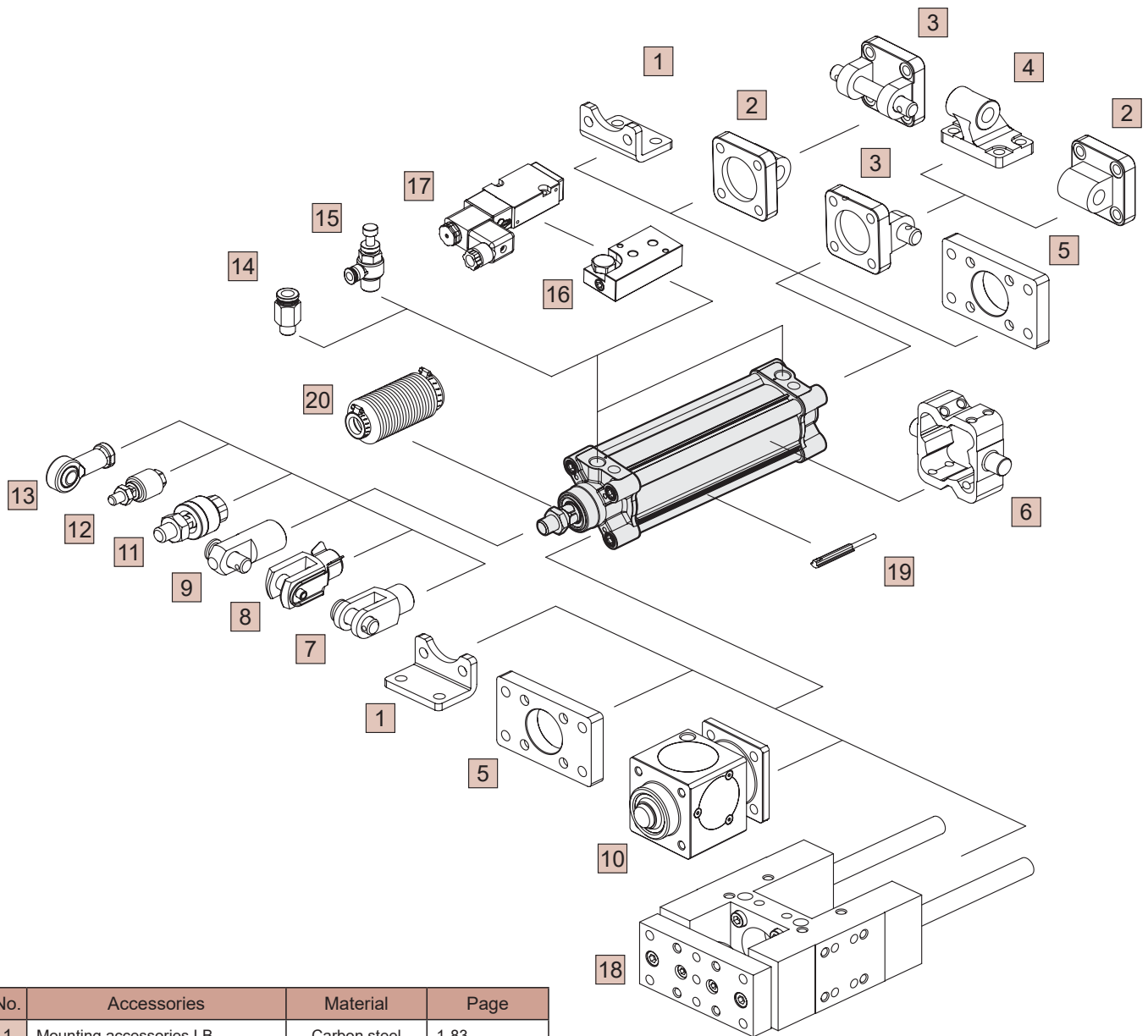

No.	Accessories	Material	Page
1	Mounting accessories LB	Carbon steel	1-83
2	Mounting accessories CA	Cast iron	1-86
	Mounting accessories CA2	Aluminum alloy	1-87
3	Mounting accessories CB+PIN	Cast iron / *1	1-86, 57
	Mounting accessories CB2+PIN	Aluminum alloy	1-87, 57
4	Mounting accessories CDB	Cast iron	1-86
	Mounting accessories CDB2	Aluminum alloy	1-87
5	Mounting accessories FAC/FBC	Carbon steel	1-84
	Mounting accessories FAC2/FBC2	Aluminum alloy	1-85
6	Mounting accessories TA/TB/TC	Cast iron	1-88
7	Accessories Y+PIN	Cast iron / *1	1-57
8	Accessories YS (Y+Floating pin)	Carbon steel	1-57
9	Accessories I+PIN	Carbon steel	1-57
10	Locking unit MCBQI3	Aluminum alloy+*2	1-92

No.	Accessories	Material	Page
11	Floating joint MFC	Carbon steel	8-2
12	Floating joint MFCS	Carbon steel	8-5
13	Female rod ends PHS	Carbon steel	8-7
14	Fitting PC (PISCO)	—	8-3 (Vol.1)
15	Speed controller JSC (PISCO)	—	8-15 (Vol.1)
16	Cylinder link seats MVSN-300-C *3	Aluminum alloy	1-69 (Vol.1)
17	Solenoid valve MVSN-220 / 300 *3	—	1-65, 67 (Vol.1)
18	Twin-guide cylinders MGTB/TU/TX	—	4-39
19	Sensor switch RCI	—	8-14
20	Protective bellows kit	NBR	—

\*1. PIN material is carbon steel. \*2. Bronze alloy.  
\*3. Only for tube I.D.  $\varnothing 40$ ,  $\varnothing 50$ .



# MCQI3 Dimensions $\varnothing 32 \sim \varnothing 100$

ISO 1552 STANDARD PROFILE CYLINDER



**11**

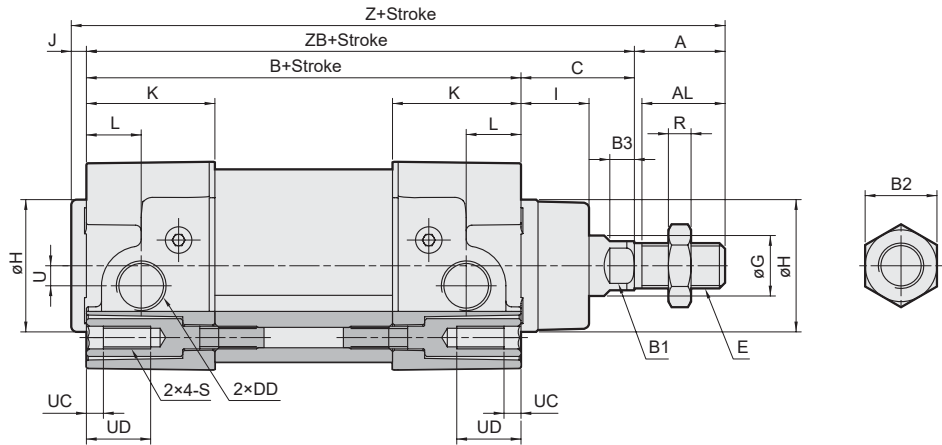
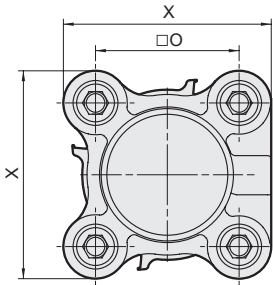

**21**

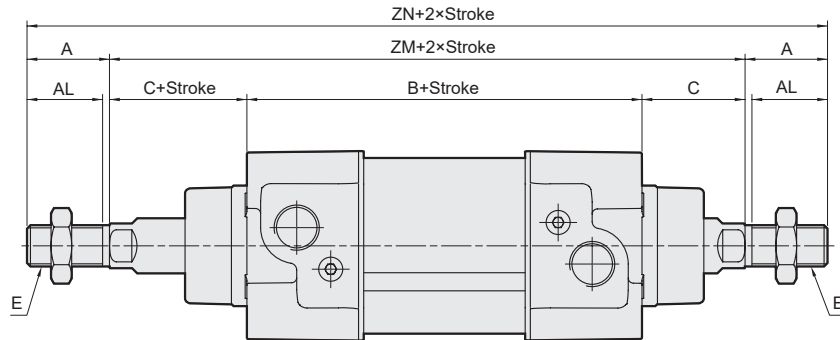

**27**

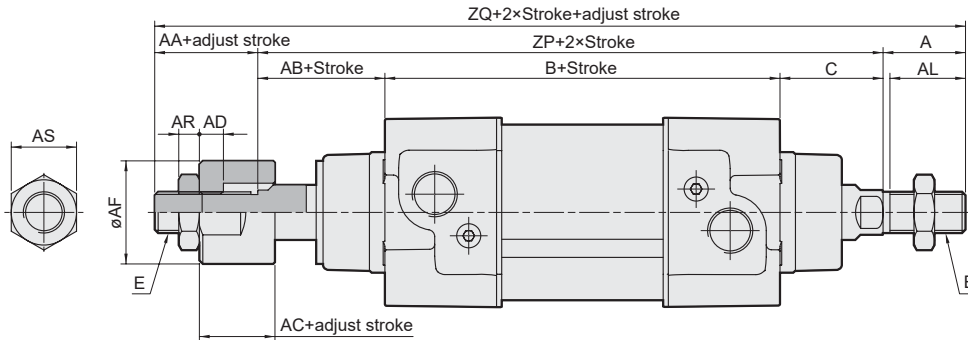

Code Tube I.D.	A	AA	AB	AC	AD	AE	AF	AL	AR	AS	B	B1	B2	B3	C	DD	E	G	H	I	J	K	L	O
32	22	16	26	12	7	M10×1.25	20	20	5	17	94	10	17	4	26	G1/8	M10×1.25	12	30	15	4	30.5	20	32.5
40	24	20	27	12	7	M12×1.25	30	22	6	19	105	13	19	6.5	30	G1/4	M12×1.25	16	35	18	4	34	14.5	38
50	32	18	34	15	10	M16×1.5	40	30	8	24	106	17	24	6	37	G1/4	M16×1.5	20	40	28	4	31	16	46.5
63	32	20	32	15	10	M16×1.5	40	30	8	24	121	17	24	8	37	G3/8	M16×1.5	20	45	26	4	33	16	56.5
80	40	32	41	20	14	M22×1.5	50	38	13	32	128	22	30	10	46	G3/8	M20×1.5	25	45	32.5	4	35.5	20.5	72
100	40	30	46	20	14	M22×1.5	50	38	13	32	138	22	30	10	51	G1/2	M20×1.5	25	55	37.5	4	37	19	89

Code Tube I.D.	R	S	U	UC	UD	X	Z	ZB	ZM	ZN	ZP	ZQ
32	5	M6×1.0	4.5	4.5	16	47	146	120	146	190	146	184
40	6	M6×1.0	5.3	4.5	16	55	163	135	165	213	162	206
50	8	M8×1.25	8.5	4.5	16	65	179	143	180	244	177	227
63	8	M8×1.25	8	4.5	16	78	194	158	195	259	190	242
80	10	M10×1.5	9	4.5	18	95	218	174	220	300	215	287
100	10	M10×1.5	13	4.5	18	115	233	189	240	320	235	305



# MCQI3 Installation of sensor switch $\varnothing 32 \sim \varnothing 100$

ISO 15552 STANDARD PROFILE CYLINDER



## ■ Installation of sensor switch

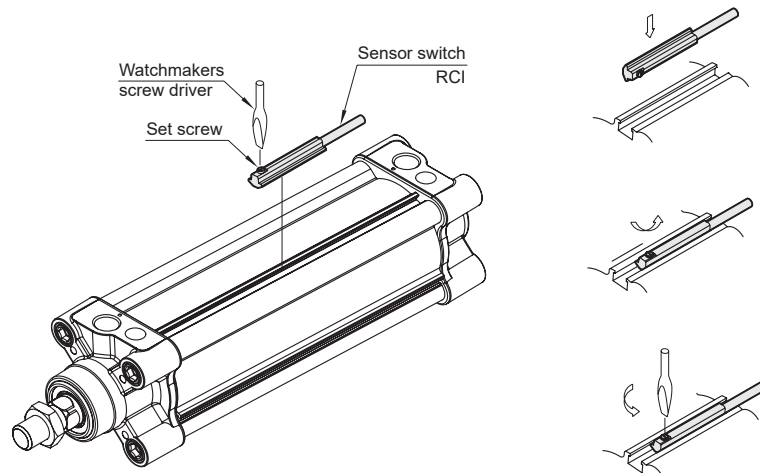

## ■ Mounting accessories

### LB

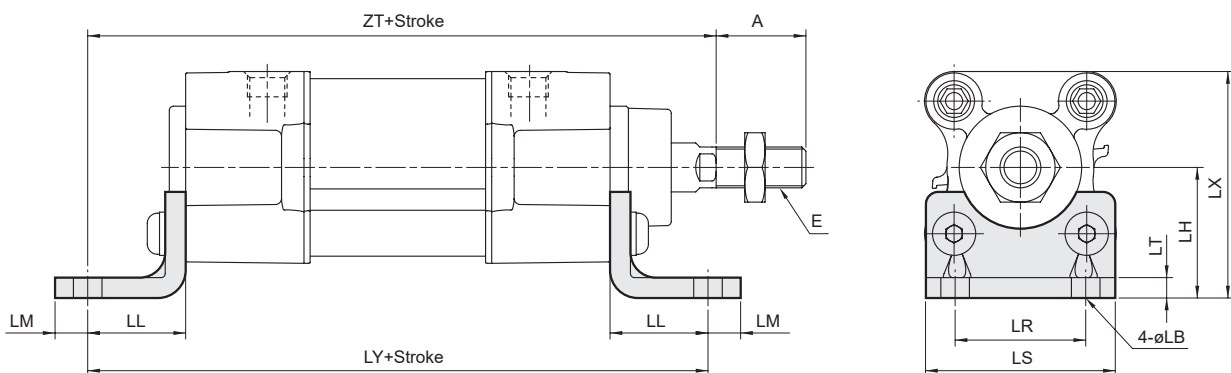

Code Tube I.D.	A	E	LB	LH	LL	LM	LR	LS	LT	LX	LY	ZT
32	22	M10×1.25	7	32	24	8	32	47	5	55.5	142	144
40	24	M12×1.25	9	36	28	10	36	53	5	63.2	161	163
50	32	M16×1.5	9	45	32	10	45	65	5	77.5	170	175
63	32	M16×1.5	9	50	32	10	50	75	5	89.0	185	190
80	40	M20×1.5	12	63	41	13	63	95	6	110.5	210	215
100	40	M20×1.5	14	71	41	13	75	115	6	128.5	220	230

# MCQI3 Mounting accessories $\varnothing 32\sim\varnothing 100$

ISO 15552 STANDARD PROFILE CYLINDER



## FAC

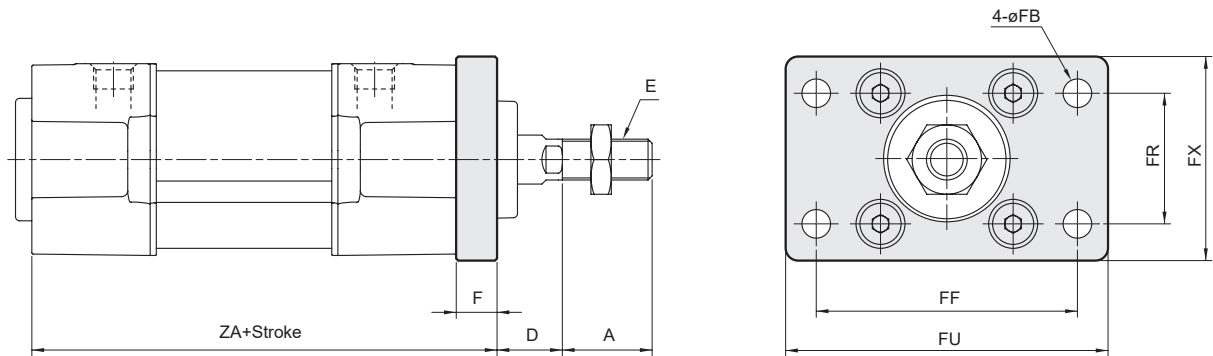

## FBC

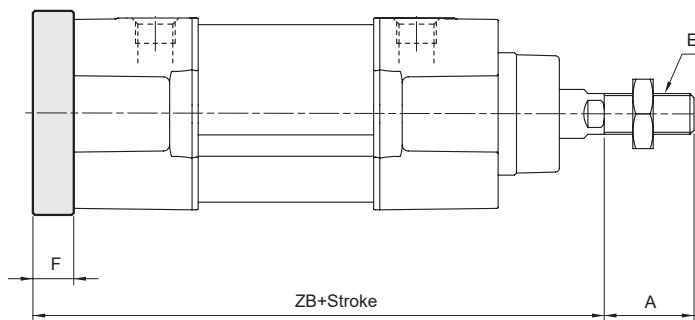

Code Tube I.D.	A	D	E	F	FB	FF	FR	FU	FX	ZA	ZB
32	22	16	M10×1.25	10	7	64	32	79	50	104	130
40	24	20	M12×1.25	10	9	72	36	90	52	115	145
50	32	25	M16×1.5	12	9	90	45	110	65	118	155
63	32	25	M16×1.5	12	9	100	50	125	76	133	170
80	40	30	M20×1.5	16	12	126	63	154	94	144	190
100	40	35	M20×1.5	16	14	150	75	180	112	154	205

# MCQI3 Mounting accessories $\varnothing 32 \sim \varnothing 100$

ISO 1552 STANDARD PROFILE CYLINDER



## FAC2

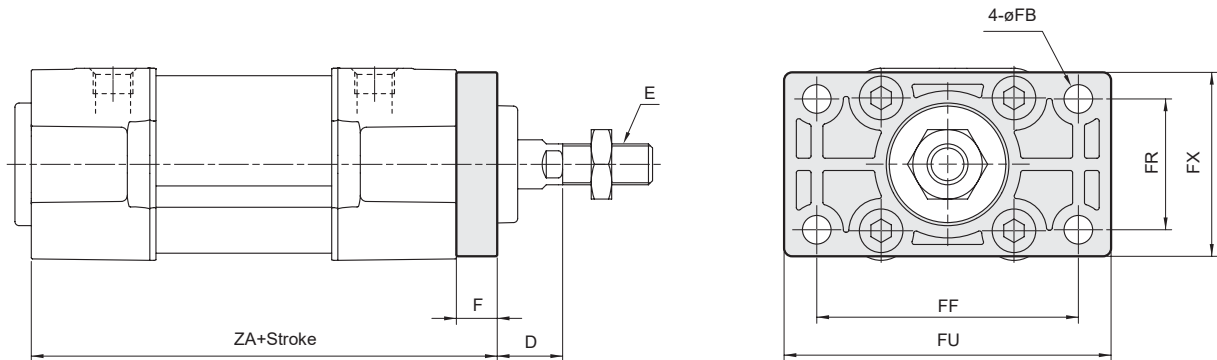

## FBC2

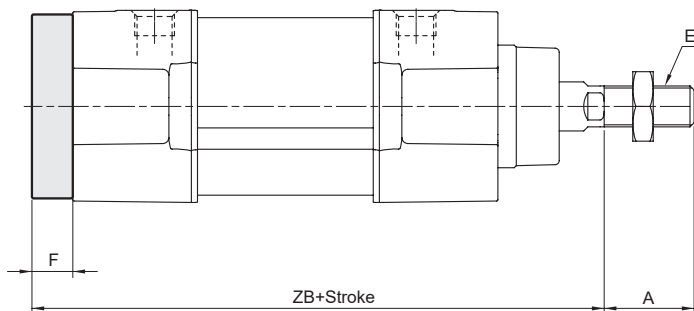

Code Tube I.D.	A	D	E	F	FB	FF	FR	FU	FX	ZA	ZB
32	22	16	M10×1.25	10	7	64	32	80	45	104	130
40	24	20	M12×1.25	10	9	72	36	90	52	115	145
50	32	25	M16×1.5	12	9	90	45	110	65	118	155
63	32	25	M16×1.5	12	9	100	50	120	75	133	170
80	40	30	M20×1.5	16	12	126	63	150	95	144	190
100	40	35	M20×1.5	16	14	150	75	170	115	154	205

# MCQI3 Mounting accessories $\varnothing 32 \sim \varnothing 100$

ISO 15552 STANDARD PROFILE CYLINDER



## CA

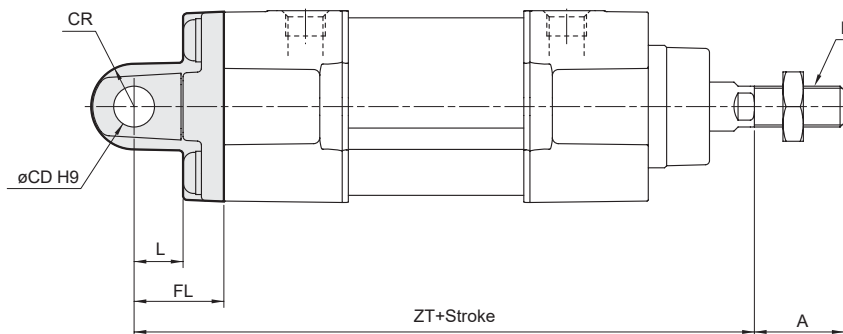
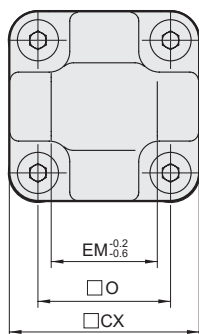

## CB

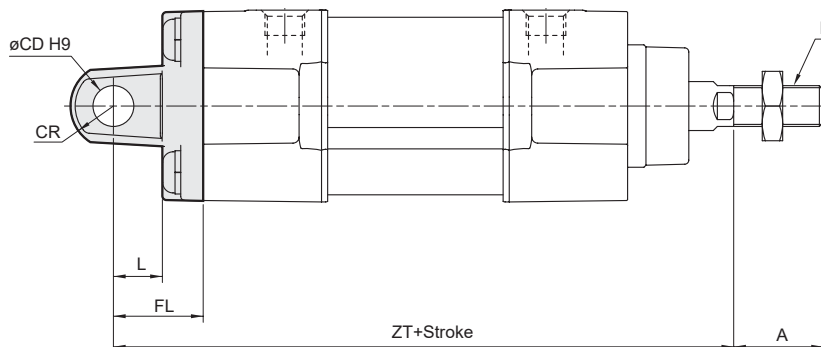
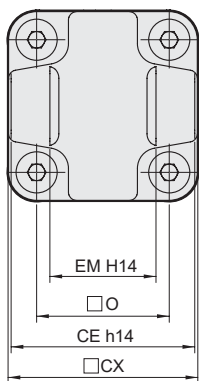

## CDB

CB+Pin (Extra purchase)

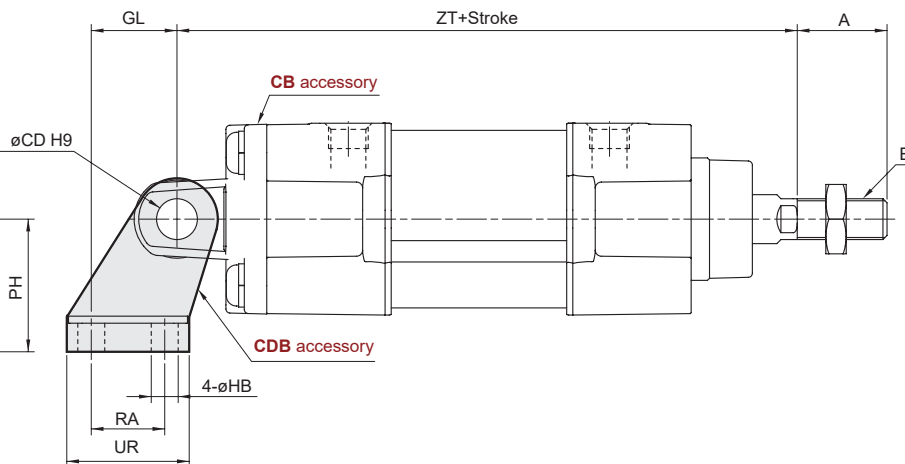
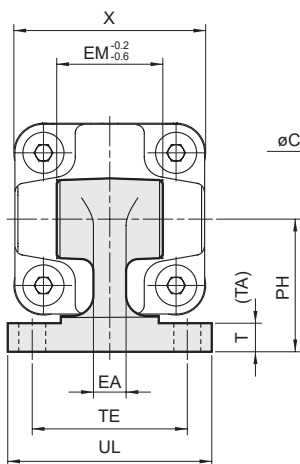

Code Tube I.D.	A	CD	CE	CR	CX	E	EA	EM	FL	GL	HB	L	O	PH	RA	T	TA	TE	UL	UR	X	ZT
32	22	10	45	R10.5	46.5	M10×1.25	8	26	22	21	6.6	12	32.5	32	18	6.5	1.5	38	50	30	47	142
40	24	12	52	R12	54	M12×1.25	10	28	25	24	6.6	15	38	36	22	8.5	1.5	41	53	34	55	160
50	32	12	60	R13	64	M16×1.5	10	32	27	33	9	15	46.5	45	30	10.5	1.5	50	65	45	65	170
63	32	16	70	R17	75	M16×1.5	12	40	32	37	9	20	56.5	50	35	10.5	1.5	52	67	50	78	190
80	40	16	90	R17	93	M20×1.5	12	50	36	47	11	20	72	63	40	11.5	2.5	66	86	60	95	210
100	40	20	110	R21	114	M20×1.5	16	60	41	55	11	25	89	71	50	12.5	2.5	76	96	70	115	230

# MCQI3 Mounting accessories $\varnothing 32 \sim \varnothing 100$

ISO 15552 STANDARD PROFILE CYLINDER



## CA2

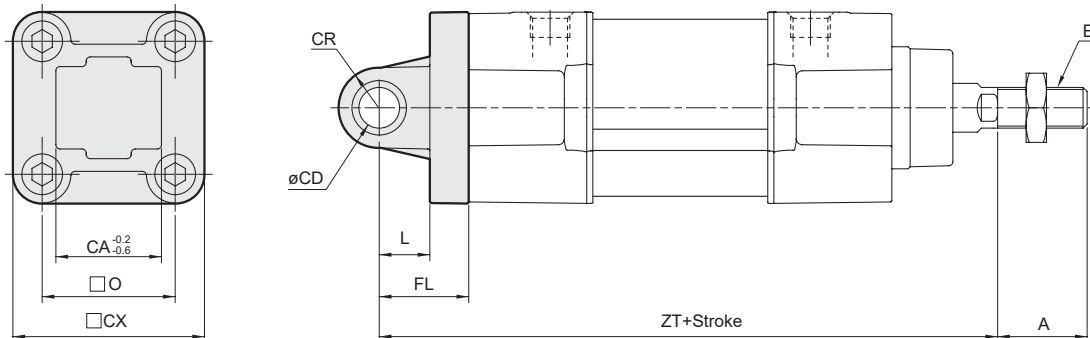

## CB2

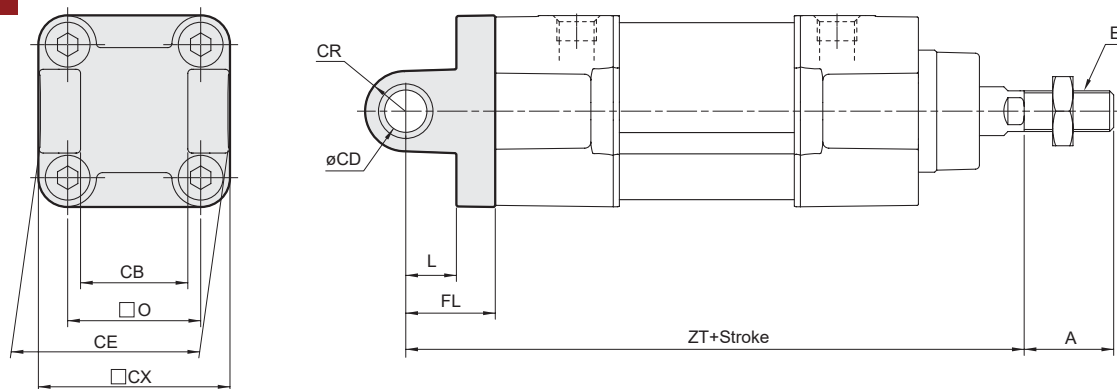

## CDB2 CB2+Pin (Extra purchase)

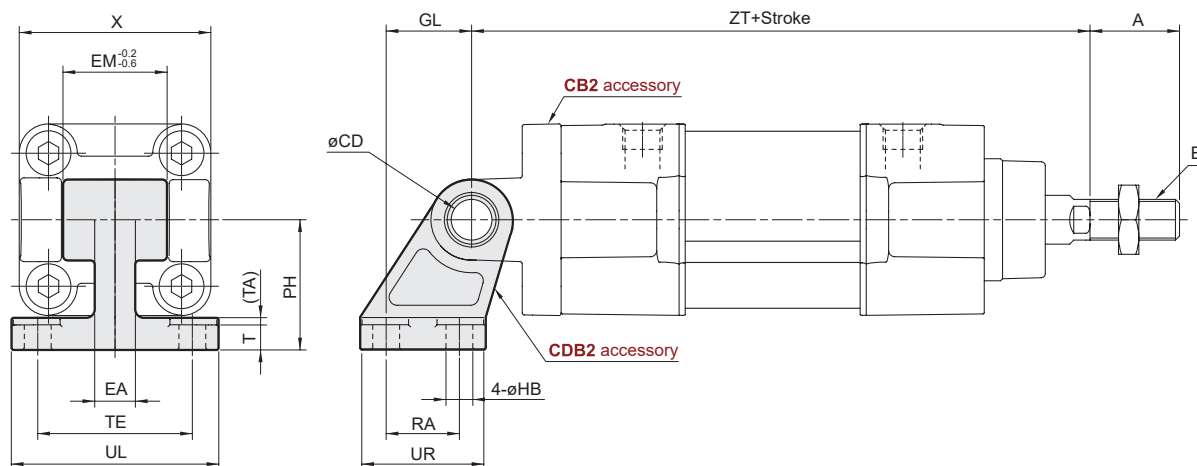

Code Tube I.D.	A	CA	CB <sup>H14</sup>	CD <sup>H9</sup>	CE <sup>H14</sup>	CR	CX	E	EA	EM	FL	GL	HB	L	O	PH	RA	T	TA	TE	UL	UR	X	ZT
32	22	26	26 <sup>+0.052/0</sup>	10 <sup>+0.036/0</sup>	45 <sup>0/-0.62</sup>	R10	47	M10×1.25	10	26	22	21	6.6	12.5	32.5	32	18	8	1.6	38	51	31	47	142
40	24	28	28 <sup>+0.052/0</sup>	12 <sup>+0.043/0</sup>	52 <sup>0/-0.74</sup>	R12	55	M12×1.25	15	28	25	24	6.6	16	38	36	22	10	1.6	41	54	35	55	160
50	32	32	32 <sup>+0.062/0</sup>	12 <sup>+0.043/0</sup>	60 <sup>0/-0.74</sup>	R12	65	M16×1.5	16	32	27	33	9	16	46.5	45	30	12	1.6	50	65	45	65	170
63	32	40	40 <sup>+0.062/0</sup>	16 <sup>+0.043/0</sup>	70 <sup>0/-0.74</sup>	R15.5	78	M16×1.5	16	40	32	37	9	21	56.5	50	35	14	1.6	52	67	50	78	190
80	40	50	50 <sup>+0.062/0</sup>	16 <sup>+0.043/0</sup>	90 <sup>0/-0.87</sup>	R16	95	M20×1.5	20	50	36	47	11	22	72	63	40	14	2.5	66	86	60	95	210
100	40	60	60 <sup>+0.074/0</sup>	20 <sup>+0.052/0</sup>	110 <sup>0/-0.87</sup>	R20	115	M20×1.5	20	60	41	55	11	27	89	71	50	17	2.5	76	96	70	115	230

# MCQI3 Mounting accessories $\varnothing 32 \sim \varnothing 100$

ISO 1552 STANDARD PROFILE CYLINDER



## TC

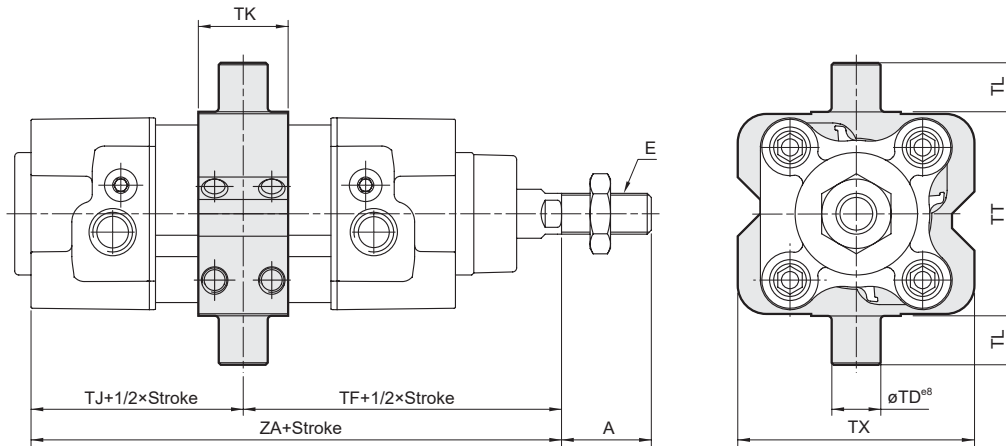

## TA

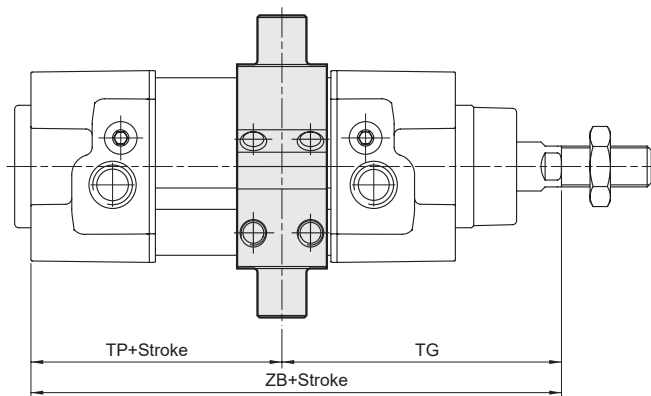

## TB

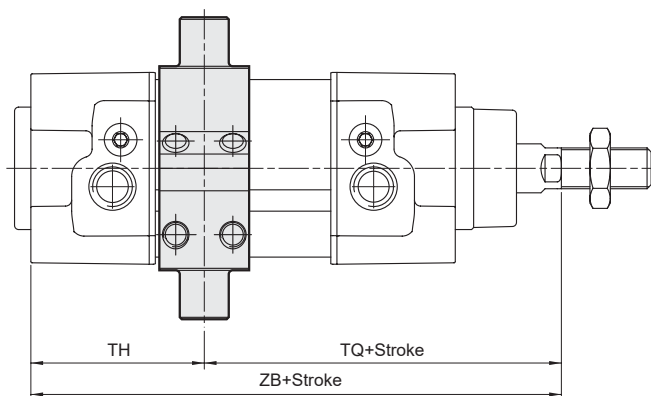

Code Tube I.D.	A	E	TD	TF	TG	TH	TJ	TK	TL	Without magnet			Magnet			TT	TX	ZA
										TP	TQ	ZB	TP	TQ	ZB			
32	22	M10×1.25	12	73	70.5	44.5	47	22	12	49.5	75.5	120	79.5	105.5	150	50	58	120
40	24	M12×1.25	16	82.5	81	51	52.5	28	16	54	84	135	84	114	165	63	70	135
50	32	M16×1.5	16	90	87	50	53	32	16	56	93	143	86	123	173	75	85	143
63	32	M16×1.5	20	97.5	90.5	53.5	60.5	35	20	67.5	104.5	158	97.5	134.5	188	90	100	158
80	40	M20×1.5	20	110	104.5	58.5	64	40	20	69.5	115.5	174	109.5	155.5	214	110	120	174
100	40	M20×1.5	25	120	113.5	62.5	69	45	25	75.5	126.5	189	115.5	166.5	229	132	145	189

# MCQV3 / MCQI3 Accessories $\phi 32 \sim \phi 100$

ISO 15552 STANDARD CYLINDER



## Y connector

$\phi 32 \sim \phi 40$

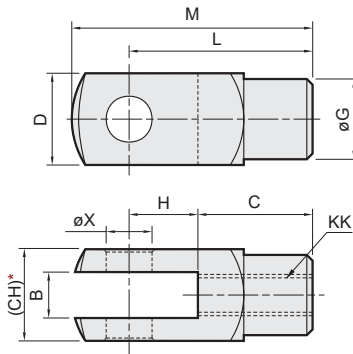

$\phi 50 \sim \phi 100$

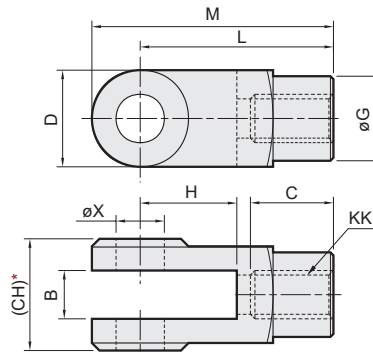

## I connector

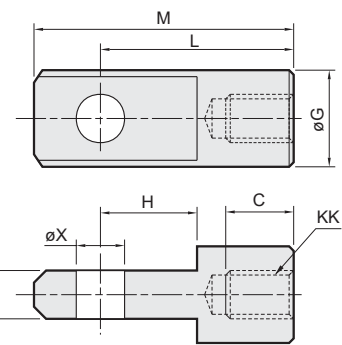

\* Please do not take the sand casting plate as the mounting plate, because we do not machine it.  
If you have this special demand, please contact our sales representative.

Code Tube I.D.	B		C		CH		D		G		H		KK		L		M		X <sup>H9</sup>
	Y	I	Y	I	Y	I	Y	I	Y	I	Y	I	Y	I	Y	I	Y	I	
32	10 <sup>+0.5</sup> <sub>+0.15</sub>	10 <sup>-0.1</sup> <sub>-0.2</sub>	20	17	19	—	19	—	ø18	ø20	20	15	M10×1.25	40	40	52	52	ø10 <sup>+0.04</sup> <sub>0</sub>	
40	12 <sup>+0.5</sup> <sub>+0.15</sub>	12 <sup>-0.1</sup> <sub>-0.2</sub>	24	21	22	—	22	—	ø20	ø24	24	18	M12×1.25	48	48	62	62	ø12 <sup>+0.04</sup> <sub>0</sub>	
50	16 <sup>+0.3</sup> <sub>+0.1</sub>	16 <sup>-0.1</sup> <sub>-0.3</sub>	28	23	32	—	32	—	ø28	ø32	32	32	M16×1.5	64	64	89	86	ø16 <sup>+0.04</sup> <sub>0</sub>	
63	16 <sup>+0.3</sup> <sub>+0.1</sub>	16 <sup>-0.1</sup> <sub>-0.3</sub>	28	23	32	—	32	—	ø28	ø32	32	32	M16×1.5	64	64	89	86	ø16 <sup>+0.04</sup> <sub>0</sub>	
80	20 <sup>+0.3</sup> <sub>+0.1</sub>	20 <sup>-0.1</sup> <sub>-0.3</sub>	33	30	45	—	40	—	ø36	ø36	40	40	M20×1.5	80	80	100	108	ø20 <sup>+0.05</sup> <sub>0</sub>	
100	20 <sup>+0.3</sup> <sub>+0.1</sub>	20 <sup>-0.1</sup> <sub>-0.3</sub>	33	30	45	—	40	—	ø36	ø36	40	40	M20×1.5	80	80	100	108	ø20 <sup>+0.05</sup> <sub>0</sub>	

## PIN

### S

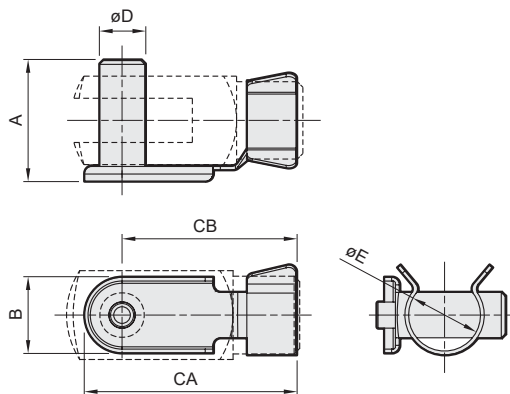

for floating pin

Code Tube I.D.	A	B	CA	CB	D <sup>d9</sup>	E
32	26	14	45	38	ø10 <sup>-0.04</sup> <sub>-0.07</sub>	17
40	31	16	54	46	ø12 <sup>-0.05</sup> <sub>-0.09</sub>	19
50,63	42	20	70	60	ø16 <sup>-0.05</sup> <sub>-0.09</sub>	27
80,100	56	30	91	76	ø20 <sup>-0.06</sup> <sub>-0.11</sub>	35

### P

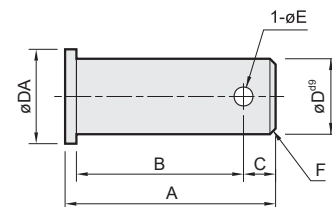

for Y & I connector

Code Tube I.D.	A	B	C	D <sup>d9</sup>	DA	E	F	Split pin
32	30	25	3.5	ø10 <sup>-0.06</sup> <sub>-0.09</sub>	14	3.2	1	3.2×20L
40	37	30	5	ø12 <sup>-0.06</sup> <sub>-0.09</sub>	16	3.2	1	3.2×20L
50,63	47	37	7	ø16 <sup>-0.05</sup> <sub>-0.09</sub>	22	4	1	4×25L
80,100	62	50	8	ø20 <sup>-0.06</sup> <sub>-0.11</sub>	30	5	1.5	5×35L

### P

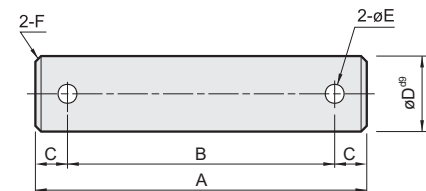

for CA & CB

Code Tube I.D.	A	B	C	D <sup>d9</sup>	E	F	Split pin
32	69	55	7	ø10 <sup>-0.05</sup> <sub>-0.09</sub>	4	1.0	4×20L
40	76	62	7	ø12 <sup>-0.05</sup> <sub>-0.09</sub>	4	1.0	4×20L
50	84	70	7	ø12 <sup>-0.05</sup> <sub>-0.09</sub>	4	1.0	4×20L
63	94	80	7	ø16 <sup>-0.05</sup> <sub>-0.09</sub>	4	1.0	4×30L
80	117	100	8.5	ø16 <sup>-0.05</sup> <sub>-0.09</sub>	5	1.5	5×30L
100	137	120	8.5	ø20 <sup>-0.05</sup> <sub>-0.09</sub>	5	1.5	5×35L